

DIRECT DRIVE SHAFTLESS PRESS CONVERSION

CSI CONTROL SYSTEM INNOVATORS

DDR Direct Drive Motor offers new Shaftless Accuracy

New DDR [Direct Drive Rotary] motor offers new definition to Shaft less Press performance and Integration. The 32 pole motor design and sine encoder resolution of 2,097,152 offers registration resolution and torque smoothness unequaled by 4, 6 and 8 pole servo motors. Motor and



drive combination offer capability of maximum performance with inertia miss match of over 250:1.

Resolution of the gravure roll drive module shaft mounted Cartridge DDR motor is the power advantage when powering large circumference gravure cylinders. 32 poles and 2 million counts per revolution do make the difference!

Integrated CSI Gravure roll drive adaptor allows integration of lateral register adjustment servo motor in single integrated unit.

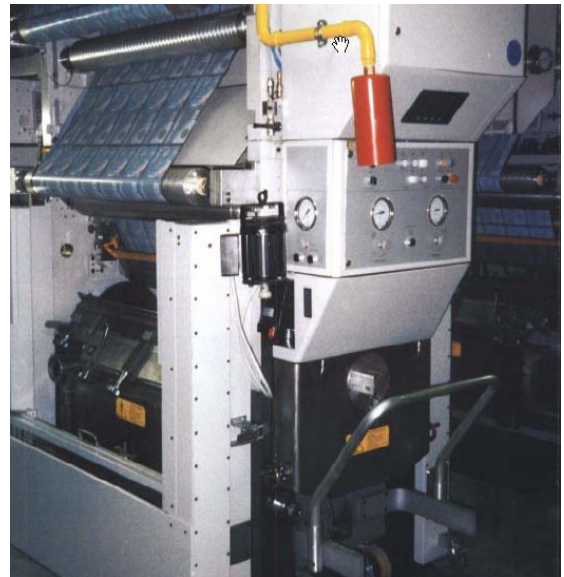

Rockwell Automation ControlLogix Integrated Motion and Software Drive Regulators

The ControlLogix controller with integrated motion and closed loop regulator function block [AutoMax like] is the basis of the CSI shaftless press electronic line shaft design.

ControlLogix™



Synchlink high speed fiber optic communication link broadcasts the master motion data [electronic line shaft data] to every drive simultaneously every 50 micro seconds.

Adaptive S-curve master reference control aids in insuring rock solid registration during acceleration, deceleration. Emergency stop is by ramped regenerative braking.

The single DriveLogix Powerflex 700S drive platform operates both DDR, Brushless servo and RPM-AC vector AC motors on all modernized press sections. DriveLogix operates with an onboard Logix engine and all network communication capabilities



PowerFlex™
700S

with DriveLogix
High Performance
with Embedded Logix

DIRECT DRIVE SHAFTLESS PRESS CONVERSION

DDR Direct Drive Motor offers new Shaftless Accuracy

The Cartridge DDR™ motor mounts uses the shaft and bearings of the CSI gravure cylinder drive adaptor. The Cartridge DDR™ design mount on a pilot and bolt circle much like a conventional motor. The design allows motor to adaptor installation or motor replacement is less than 30 minutes shipping container to operation.

Motors are available with continuous torque to 376 lb-ft. and peak torque of 750 lb-ft.

Sine encoder feedback provide resolution to 2,097,152 counts per revolution.

Housings are available for UL Class1 Division 1 areas.

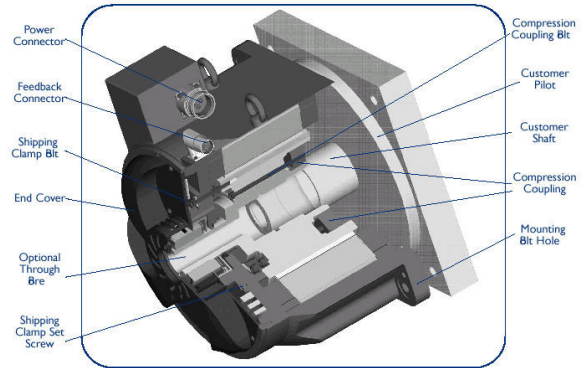

Integrated ControlLogix System links Press Drive Control , Logic and MMI

The ControlLogix platform includes multi-language programming, real time multi- task program execution, and multi-network interface. The ControlLogix platform integrates Drive Control, Press Logic and operator interface MMI workstations using high speed networking.

Clock timed program execution insures accurate drive regulator control , print registration and PLC logic functionality

Ethernet/IP connect-ability allows single point access of all system components for management information, monitoring product quality, speed, tension and registration monitoring, maintenance troubleshooting and drive control firmware upgrade.

Ethernet /IP, Synchlink and SERCOS networks are used in the overall networked based press drive and control system strategy.

Direct network interface on all drives allow drive parameter download and time critical communication with out analog or digital interface wiring.

The single DriveLogix Powerflex 700S drive platform operate both DDR, Brushless servo and RPM-AC vector AC motors all modernized press sections. DriveLogix operates with an onboard Logix engine and includes all network communication capabilities

ControlLogix, Powrflex700s, Synchlink, DriveLogix are trade names or trademarks of Rockwell AutoMation

Cartridge DDR is a trademark of Dynaher Motion

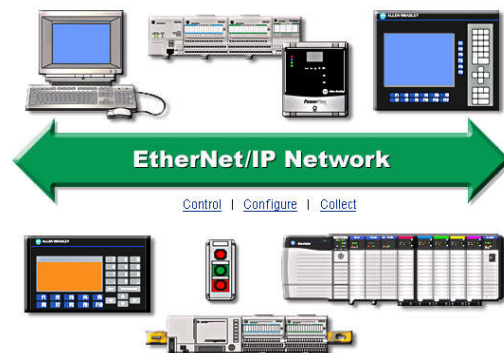

Pub2004-DDRP-1

(Plant)
Fox Bluff Corporate Center
1301 Bowes Road, Suite A
Elgin, IL 60123
(mail) P.O. Box 7010, Elgin, IL
60121

Phone: 847-741-0007
Fax: 847-741-7710
Email: sales@controlsysteminnovators.com

CSI CONTROL SYSTEM INNOVATORS